

 Thrane & Thrane

## TT-3086A Capsat® Fleet55



### Features

- Online, all the time with 64 kbps Mobile Packet Data Service (MPDS) (Spot beam only).
- 64 kbps ISDN (Spot beam only). Voice, fax, data.
- 3.1 KHz Audio (Spot beam only).
- Mini-M voice. Global coverage, 78° north to 78° south.
- 9.6kbps Fax capability.
- Simple installation due to light weight and compact transceiver and antenna design.
- Rapid configuration via handset or PC.
- Compact, convenient, cost-effective and reliable.
- Prepared to operate on the next generation Inmarsat Satellites, I4.

### Description

The TT-3086A Capsat® Fleet55 communications terminal offers high-speed and cost effective voice and data communication based on either the MPDS (Mobile Packet Data Service) protocol or 64 kbps ISDN PPP connection.

With MPDS you are only charged for the amount of data transferred, not for the time the channel remains open, making it the most economic and convenient solution for e-mail, small and medium size transfer, LANs, VPNs and Internet.

ISDN service provides a high-capacity channel with a constant data stream and are usually preferable for up- or downloading large files.

The compact antenna is 68 cm high, has a diameter of just 57 cm and weighs only 18 kg. It is line replaceable for easy service and maintenance.

The Capsat® Fleet55 transceiver provides a constant two-way link to Inmarsat satellites offering Inmarsat Fleet MPDS communications. The system is accompanied by user-friendly software, which enables simple configuration from a standard PC.

The Capsat® Fleet55 transceiver and the antenna provide the hub for online communication all the time via desktop phones, payphones, DECT phones and fax machines.

Connected to an IP router, the Capsat® Fleet55 terminal can integrate the vessel 24 hours a day with onshore management systems via the Web, including e-mail and Internet services.

The TT-3086A operates through the established network of Inmarsat and GPS satellites with interconnection to the international fax and packet switched data network, offering fast and reliable transfer of information, 24 hours a day.



Thrane & Thrane

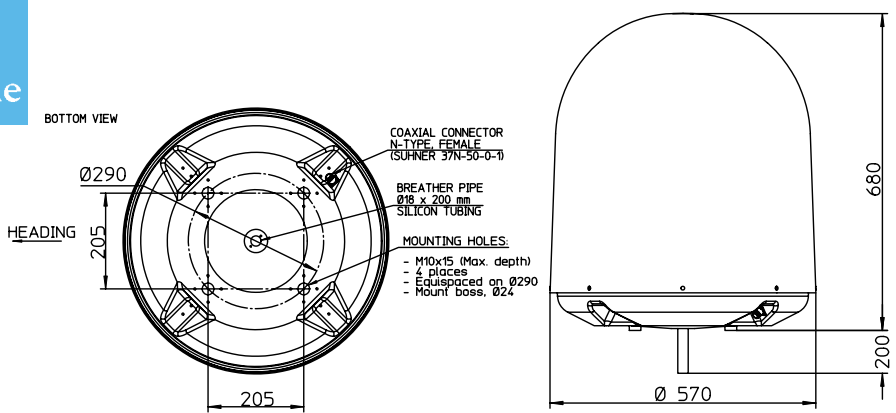

## Specifications

### Approvals:

Inmarsat Fleet55 approved.  
Compliant to FCC, title 47 part 25, section 25.216.  
Compliant to RTTE, CE Marked.

### Frequency Band:

Rx : 1525.0 – 1559.0 MHz.  
Tx : 1626.5 – 1660.5 MHz.  
Ch. spacing: 1.25 kHz – Rx.

### Recommended Antenna Cable:

N/N male, max. cable loss 10 dB at 1.6 GHz, 0.5 Ω at DC.  
1 – 10 m, RG223.  
10 – 30 m, RG214.  
30 – 50 m, SA07272.  
50 – 70 m, SA12272.

### Global Service:

Voice: 4.8 kbps Mini-M voice.

### Spot Beam Services:

Voice: 4.8 kbps Mini-M voice.  
Group 3 fax capability.  
Fax 9.6 kbps  
MPDS 64 kbps shared channel.  
ISDN 64 kbps PPP channel.

### Antenna Connector:

50 Ω N female.

### Interfaces:

1 RJ-45 ISDN NT1 S/T Bus.  
3 RJ-11 for 2-wire telephone/fax.  
2 DSUB-15 for 4-wire handset.  
1 50 Ω TNC female for antenna.  
1 DSUB-9 NMEA 2000/183.  
1 DSUB-9 RS-232 Port, 115 kbps.  
4 Discrete I/O.  
1 Power Port, 24 VDC floating.  
1 On/Off button.

### Power Supply and Consumption:

24 VDC -10% / +30%.  
Input circuit: floating.  
Max 200W

### Environmental Conditions:

Ambient temperature:  
-25 to 55 °C.  
Relative Humidity:  
95% non-condensing at +40 °C.

### Vibration (antenna):

4-10 Hz 2.54 mm, 10-15 Hz 0.76 mm,  
15-25 Hz 0.40 mm, 25-33 Hz 0.23 mm.

### Mechanical Shock:

20g/1 ms half-sine.

### Ship Motions:

Roll +/-30 deg, Pitch +/-10 deg, Yaw +/-8 deg, Surge +/-0.2g, Sway +/-0.2g, Heave +/-0.5g, Turning Rate +/-6 deg/s, Headway 30 knots.

### Dimension and Weight:

Antenna (TT-3008F):  
680mm x Ø570, 18 kg.  
Transceiver (TT-3038C):  
53.75 x 377 x 163.7 mm, 2.6 Kg.  
Cradle (TT-3622C):  
160 x 61 x 27 mm, 0.15 Kg.  
Handset (TT-3620F):  
200 x 52 x 33 mm, 0.25 Kg.

■ Our products are under continuous research and development. Any information may therefore be changed without prior notice. Capsat is a registered trademark of Thrane & Thrane A/S, Denmark.



Distributor:

Thrane & Thrane A/S  
Denmark

info@tt.dk  
www.tt.dk